

# **BDCOM projects for networking communication**

**Inshine 2006.3.21**

## **Foreword**

**Shanghai Baud Data Communication Co., Ltd. (BDCOM)** is committed to designing and manufacturing quality networking products since its inception in 1994. As the maker of China's first router in 1998, today we are proud to supply total solutions to our customers around the globe, working hard to meet emerging challenges, and taking the initiative to ask questions of tomorrow.

With our complete product lines of routers, switches, transfer equipments, IP voice products, IP video products, firewalls, and network management software, we have served customers spanning across many industries and fields, such as telecommunication carriers, ISP's, financial services, educational institutions, postal services, taxation services, meteorological services, military services, police authorities, etc. Besides over 1000 large enterprises in major industries, small to medium businesses are also our greatest treasure in our established customer base. We highly value their trust, and endeavor to serve our society with better products and services. Till the end of 2004, hundreds of thousands of BDCOM networking devices have been running all over the world to keep people and enterprises connected.

BDCOM is headquartered in Zhangjiang Hi-Tech Park, Shanghai, China, where our R&D center is located. More than 30 sales and technical support centers in the country strive to exceed our customers' expectation. As a leading networking solution provider, we set out to provide our customers with smarter, faster, and more reliable products at lower prices, and with better services.

BDCOM are always committed to offering hi-performance and hi-reliability networking projects to our customers around the globe. Next we will show you some representative projects including educational institutes, financial institutions and national defences.

## **Chapter 1 Educational Institutes**

### **1.1 Small-and-Medium sized network**

This project is suitable for the elementary and senior schools which have small or middle size networks. Considering the cost, this project does not adopt redundancy structure. In addition, its requirement for stability is not so high.

#### **Topology Structure:**

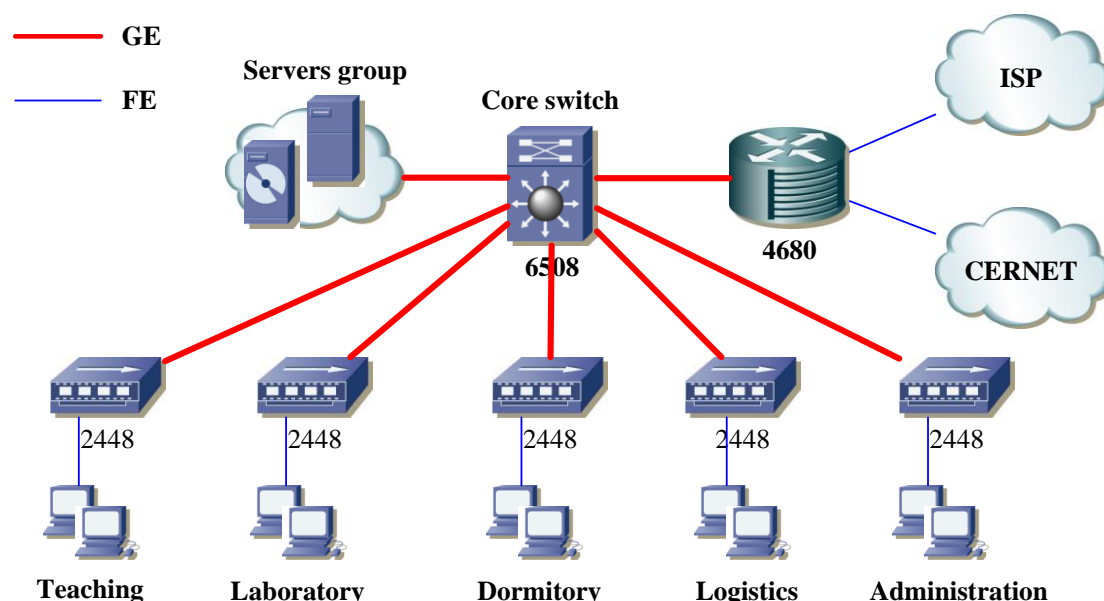
**Interpretation:**

Considering the stability of network, we choose 4680 router as access from Internet, and 6508 switch as the core switch, which are hi-performance and sufficient to ensure the stability of small-and-medium sized education network.

Due to the total number of users no more than 1000, the project adopts core-access two layer network structure. Low-complexity can bring hi-performance to the network. We can use S2448 as the access layer switch, and connect core switch by 1000M uplink ports to ensure the bandwidth. Downlink use 100M line to users to ensure the daily teaching work, etc.

The whole project is on the premise of low-cost and hi-performance. If clients want to expand the network in the future, we can also make use of additional slots in S2448 to complete the expansion, which fully considers the expansibility of the network, etc.

**Advantage:**

Small size, a little amount of data, the requirement for reliability is not so high, and do not need redundancy. Cause no more than 1000 users, it adopts single line or double line.

Because the establishment of the net is not complex, we only need core-access two layers mode network. The structure is simple and easy-manageable. All above, also including low cost, completely satisfy the requirements of small-and-medium sized network.

**Shortcoming:**

Due to no redundancy configuration, core switch is required to have high stability. The whole network will not work once there is something wrong with the core switch.

**1.2 large sized network**

This project is suitable for higher education organizations, such as universities and colleges, which have large network system and thousands of users. So they require high stability, security and expansibility.

**Topology structure:**

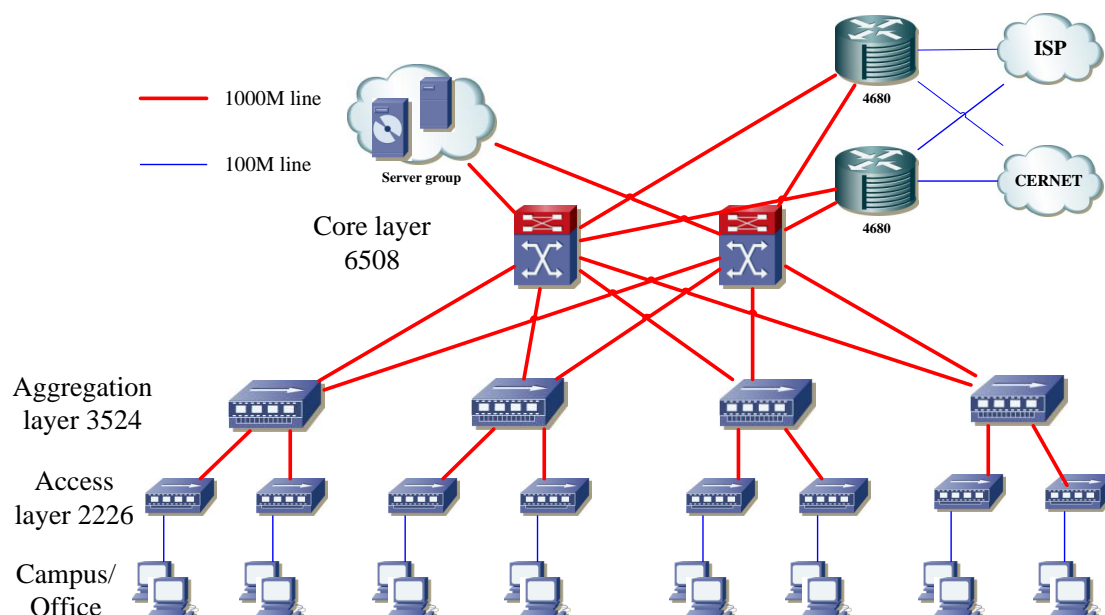

### Interpretation:

Access layer and core layer switches use redundancy backup mechanism and emphasis the high reliability of whole network. Choosing 4680 as access router and 6508 as core switch is to give prominence to the high-performance and high-stability of the network.

Aggregation layer using S3524, which support all 1000M ports uplink and downlink, to make sure the bandwidth of users. High rate of taking in and sending out also guarantees the fluency of data transferring, supports cluster technique and high expansibility.

Use 2226 as access layer router, high performance and security, supply L2~L7 ACL which guarantees the safety of the network from access layer.

### Advantage:

Adopting hot standby as core layer ensures the reliability of the center network.

Using 4680 hot standby as access layer router ensures the reliability of the access from Internet.

Adopting core-aggregation-access three layers net structure ensures the stability of the network. If there is something wrong with a certain local network, it will not influence the other networks.

The access layer switch supports security authentication, like 802.1X, to ensure the security of the network.

Support network management.

### Shortcoming:

High cost, the distribution layer does not adopt redundancy, if there is something wrong with certain layer switch, it will result in the users in downlink layer switch not work.

## Chapter 2 Financial Institutions

In order to satisfy the business demands, finance institutions have a high requirement for low-delay of the net. The line should be stable and reliable, and the network should have high security. Besides, the network can't be so complex for management. Usually the bank

network is the whole one and includes three levels, which is headquarter/branch/sub-branch level. The data should be transferred immediately and in time among banks. Usually we use DDN net, and a PSTN line to dial-backup. Cause a large amount of ATM terminals provided by bank, we should offer fixed terminal services through terminal routers.

**Topology structure:**

**Headquarter:**

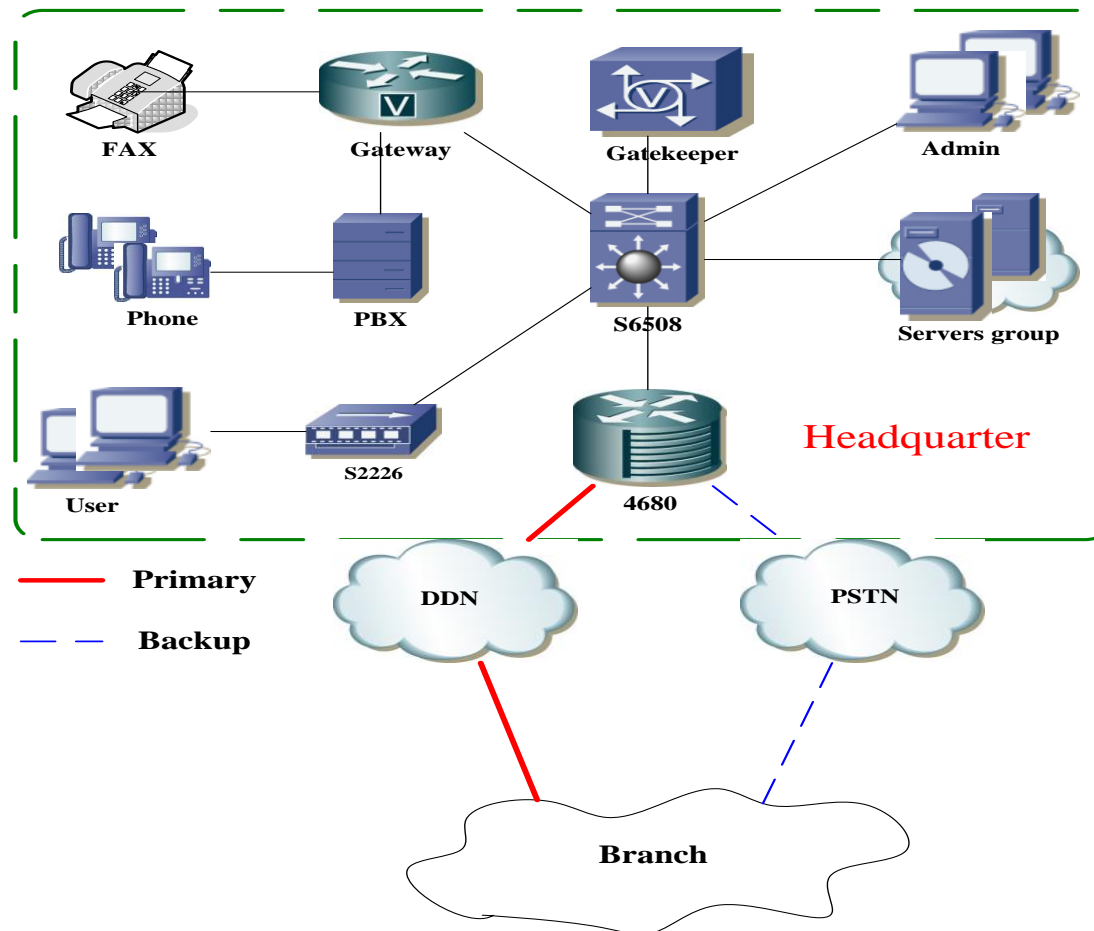

**Branch:**

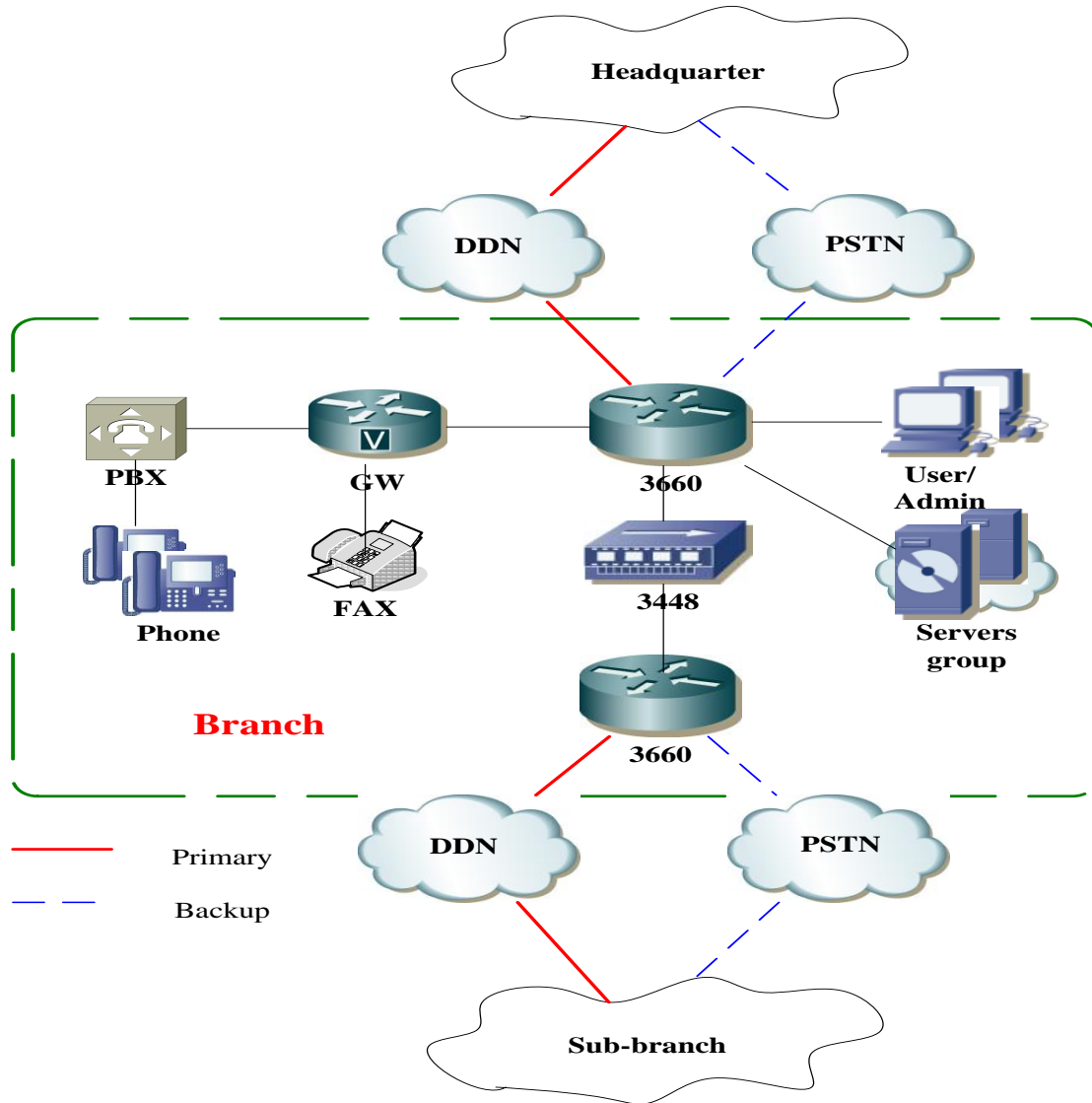

**Sub-branch:**

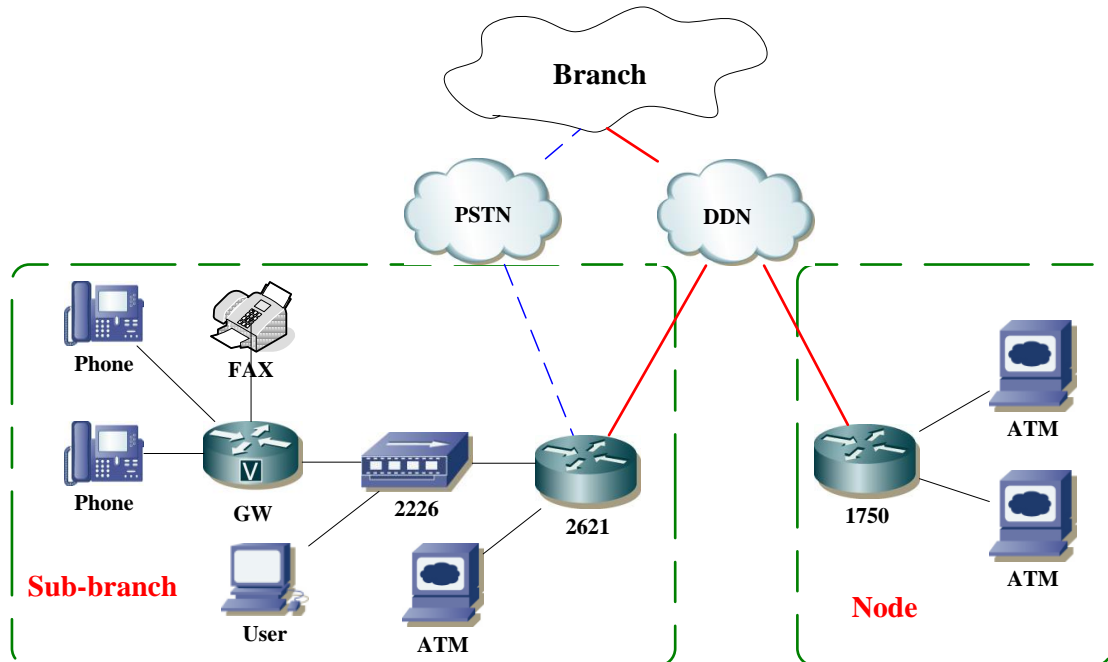

**Interpretation:**

This network design integrates voice and data. The three level of network structure among the HQ, Branch and Sub-branch, fully considers the network's stability, economic character and reliability. In order to satisfy the security requirement, we should make a redundancy design, but for the cost, we use the method of line-backup instead of router redundancy standby. In this way, we can perfectly achieve the purposes both of reliability and economical character. Because of the great amount of data processing in center net, we use 6508 as the core router and 4680 as the core switch, which are reliable and stable for use. In addition, we need additional downlink switches to satisfy the larger number of users. The hi-performance and hi-security switch S2226 is a good choice. Branch banks choose 3660 as the uplink and downlink access router, its high rate of price-and-performance is absolutely suitable for the branch's network size. Switch 3448 with 48 100M ports can satisfy the demands of users. For less users and datum in sub-branch, we recommend 2621 router and 2226 switch. 2621 provides 18 async serial ports at most, and supports the binding of 18 ATM terminals or 18 lines access by dialing or DDN line at the same time.

**Advantage:**

The line backup guarantees the reliability of the net. The switch time between primary and backup line is no more than 1 minute, which ensures the business smoothly operated in unstable net environment.

Take full consideration of the economic character, and choose the most right products to make full use of all net equipments.

The network integrating voice and data saves the calling costs among banks.

We can add video devices in the expansible network and integrate video, voice and data into one net..

**Shortcoming:**

The network mostly consists of single equipment. So the network will be influenced by certain equipment having some trouble.

According to economical principle, the backup line we choose is PSTN line. So the bandwidth after dialing will influence the time of business.

## **Chapter 3 National Defences**

### **3.1 Military networks**

The military network needs the highest safety because of involving a national security, required for high reliability and stability in the meantime, in consideration of these factors, it's better to use VPN for communications. Meanwhile, every section of troops should be insulated form each others, hereby we adopt three-layers networks constructions, so the switches required high capability on partition VLAN, management and port security. The reliability requests functions of HSRP, and line backup for important sector, other less-important sectors use line backup or without any backup. As concerns states security, we can't display a topology of troops network.

**Suggestion as follow:**

Army, headquarters adopt double 4680 connect Internet, two router hot-standby, in order to guarantee reliability of connection .In the center, use double 6508 switch, guarantee reliability and

stability. Lower layer use 3224 as the aggregation switch, configure VLAN, Provide 802.1X or radius authentications for special department access. Access layer use 2026 switch, economy and reliable, can meeting commonly applications, but for the special department should use 2226 or even higher switches, like 3224. Branch offices, use 3660 connect to Internet, line backup guarantee reliability, use 3224 as aggregation switch, access layer us 2026, each department adopt VLAN isolation.

Access between branch offices, we suggest that, use 3660 router, with IPSec VPN, guarantee safety of communication, avoid hackers wiretapping. Meanwhile, high throughput may guarantee data traffic work in real-time.

**3.2 Police network**

As another backbone of national security, the police network also required high safety and reliability as the troop networks, meanwhile, information need freely communicate, so need a integration of voice and date, the project also should consider about the economy .Using provincial-city-town-countryside 4-layer model, the network bigger, so required easy maintenance.

**Topology structure:**

**Province:**

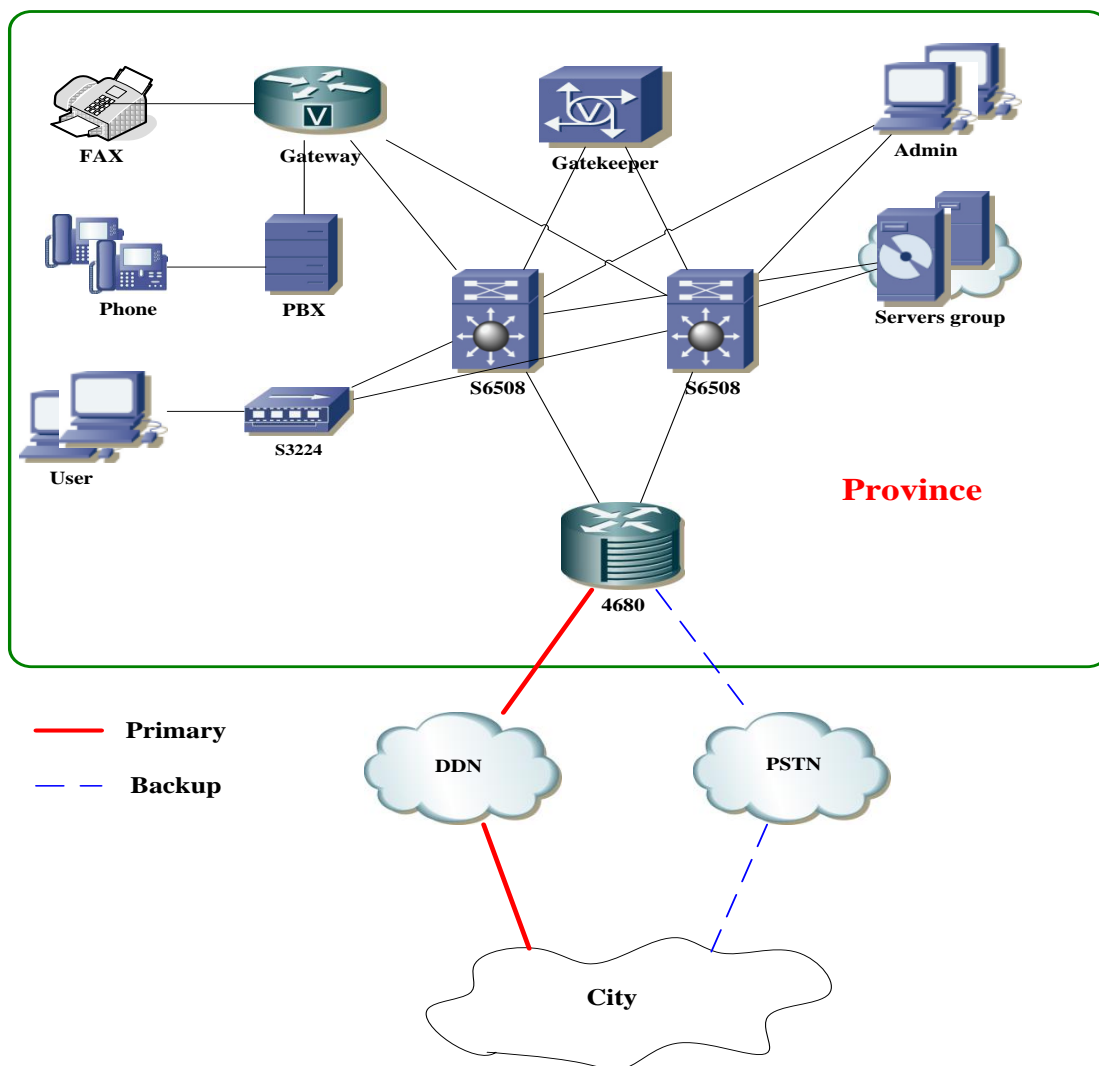

**City:**

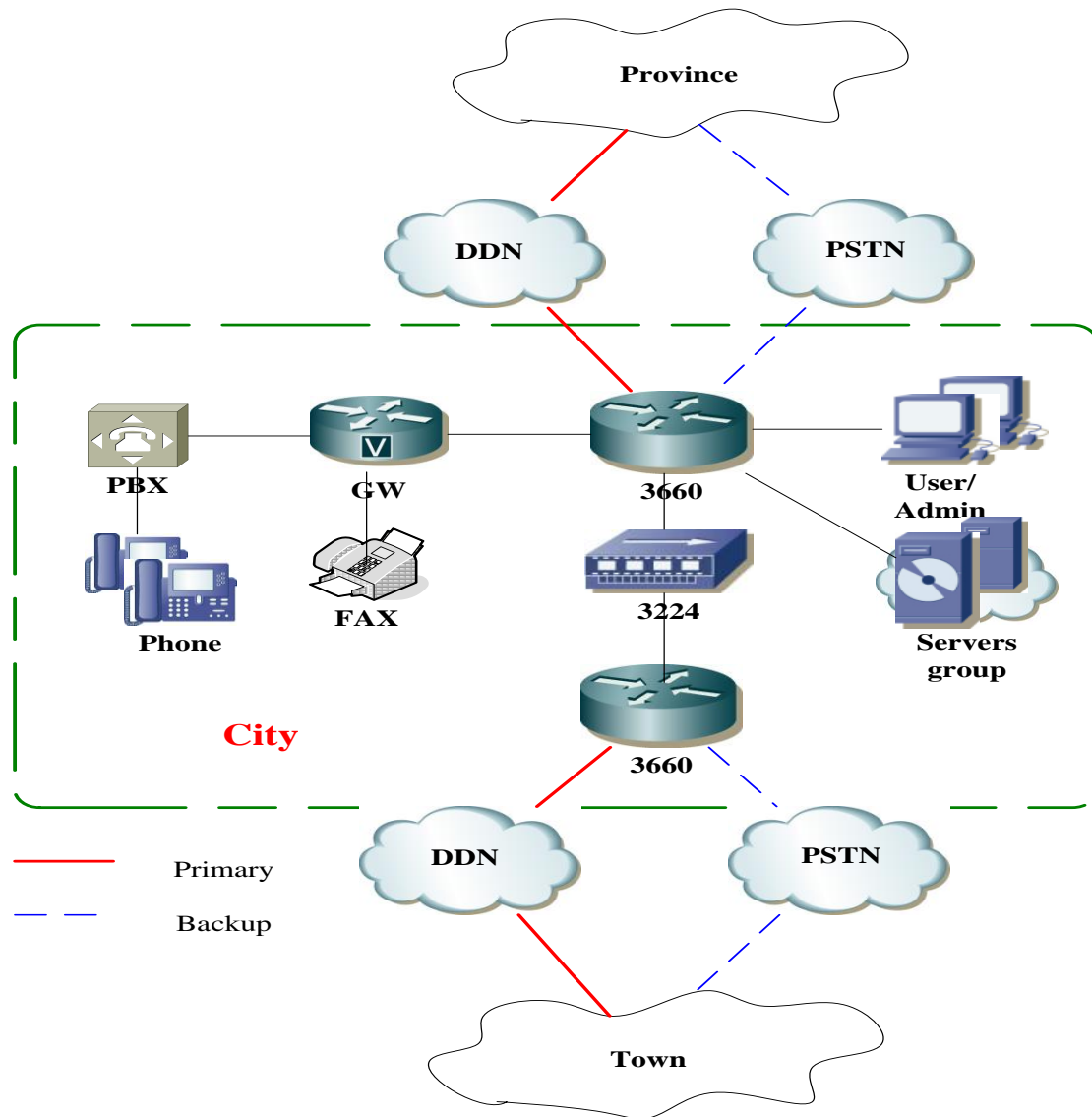

**Town:**

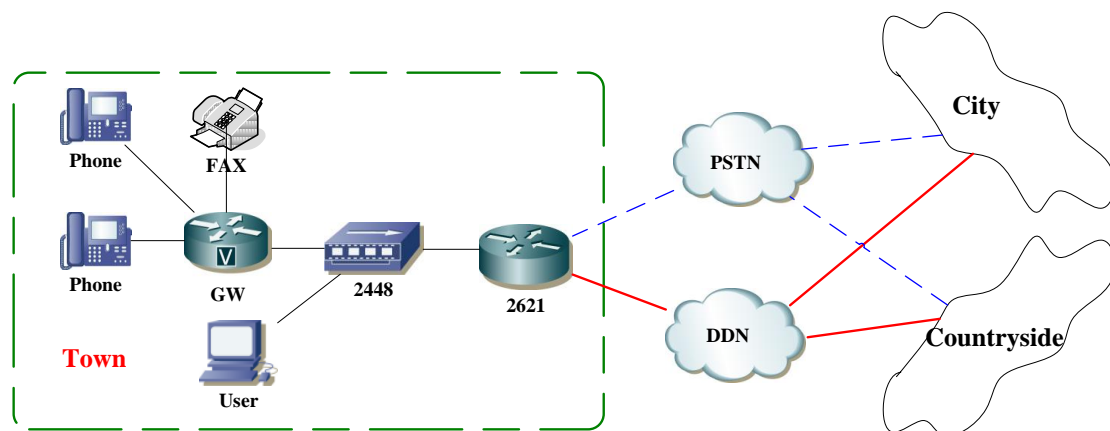

**Countryside:**

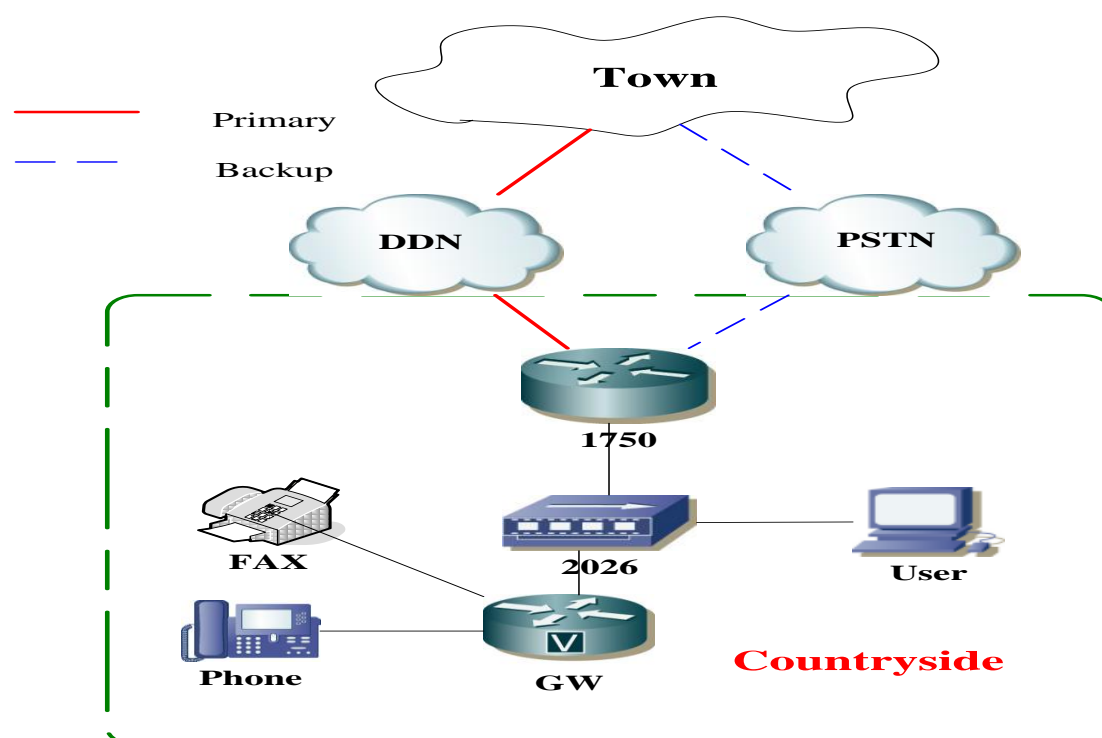
**Interpretation:**

The province class network work as a core of the province, needing the highest stability and safety. Using 4680 as access router, 6508 as core switch, adopt double line backup, core switch using hot-standby, guarantee network reliability. Using 3-layer construction, guarantee network stability. The city class network use 3660 as access router, double line standby, using 3224 as core switch, and this type switch is high cost-effective, can meet this application all-right. The county class network use 2621 as access router, double line standby, using 2448 switch, as the county date flow not much, end user not so many, one 2448 can meet this, and if need more ports, we can us the slots to make a stack. The town class network use 1750 as access router, double line standby, using 2026 switch, and the town users even less, so the 2026 can meet this application.

The access between the layers, using L2TP, can guarantee network security.

**Advantage:**

The reliability is the first principle, and this design considered that well.

The integration of voice and date, we can expand video function in the future

**3.3 Prison Network**

The structure of prison network is relative simple. Their most important requirement is a reliable connection with the servers in center computer room. The data quantity is not so big and some places need voice network.

**Topology structure:**

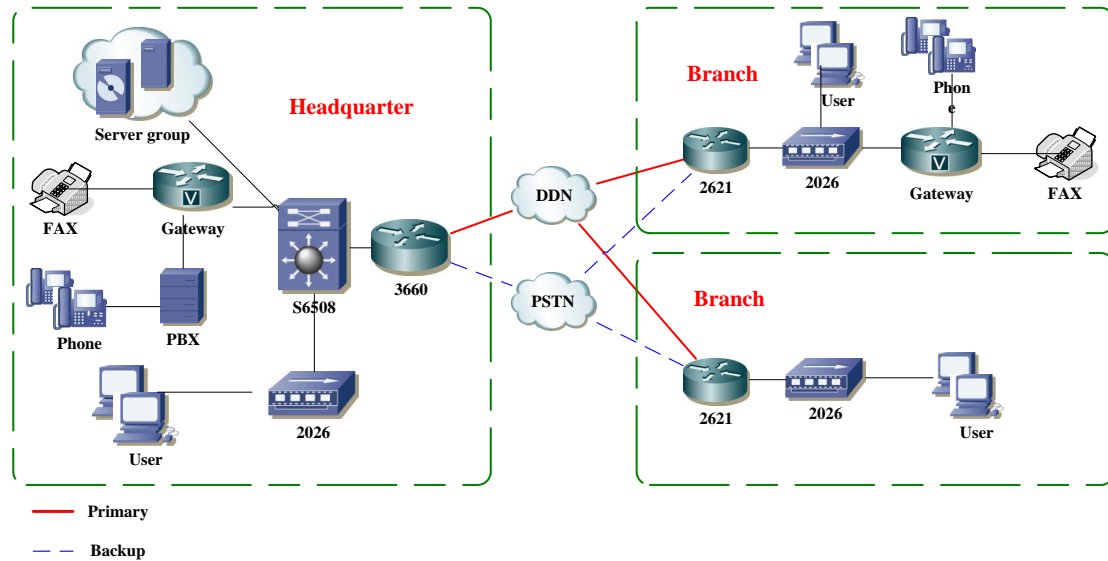

**Interpretation:**

As the core of the whole net, the servers in center computer room require high stability and reliability. So we choose 6508 as the core switch. At the same time, we use 3660 as the access router for the small quantity of data. The performance-and-price rate is high. Each branch uses 2621 as the access router and switch 2026 to ensure the daily operation.

**Advantage:**

The simple net structure is easy manageable and stable. According to stability and economical principle, all selected equipments are hi-performance and have relative low prices.